

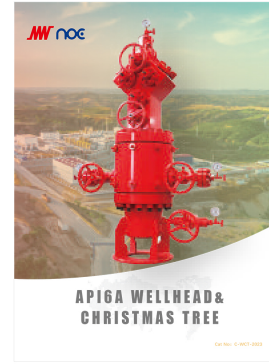

Product Summary



Subsea Products



WELLHEAD & CHRISTMAS TREE

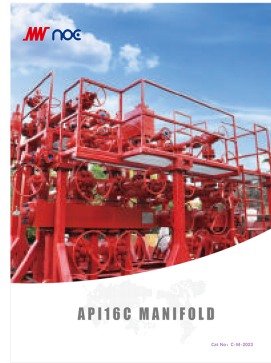

MANIFOLD



FRACTURING PRODUCTS

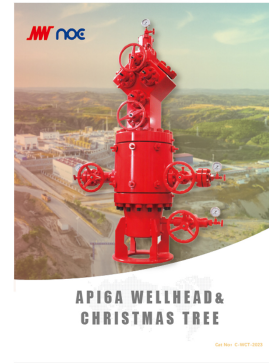

WELLHEAD & CHRISTMAS TREE



To be a Global Leading Manufacturer of Flow Equipment
Complete Solutions for Smart High Pressure Flow Equipment

Neway Oil Equipment (Suzhou) Co., Ltd
Address: No.999 Xiangjiang Road,
Suzhou New District, P.R.China
Tel: 0512-6708-1952
Email: noe@neway.com.cn
Website: www.newayoilequipment.com
Post: 215129



WEBSITE



WECHAT

API6A ACTUATOR

Introduction.....3

AD Actuator4

AP Actuator8

AH Actuator12

AC Actuator16

DH Actuator20

Actuator Redress Kits

 1) AD actuator Redress Kits.....25

 2) AP actuator Redress Kits.....27

 3) AH actuator Redress Kits.....29

 4) AC actuator Redress Kits.....31

 5) DH actuator Redress Kits.....33

Gate Valve Redress Kits

 1) GBM Gate Valve Redress Kits.....36

 2) GBC Gate Valve Redress Kits.....37

 3) GBS Gate Valve Redress Kits.....38

 4) GBW Gate Valve Redress Kits.....39

Manual Override.....40

Lock Open Cap.....41

NOE pneumatic and hydraulic actuators are used in drilling, wellhead, distribution, manifold and storage applications both on and off-shore. The actuators are designed to actuate Noe's GBM, GBC, GBS and GBW gate valves, as well as valves produced by other manufacturers.

NOE actuator accessories are designed to be used in conjunction with pneumatic and hydraulic actuators manufactured by NOE. The accessories listed in this brochure are not designed to work with other manufacturer's actuators.

Every actuator and accessory manufactured by NOE is designed to provide trouble-free service in a variety of severe operating conditions and is manufactured to exceed international recognized standards such as API, ISO and ASME.



AD Actuator Introduction

NOE's AD pneumatic diaphragm actuators are designed to be used with most manufacturers' gate valves. The simple design and operating principle make these actuators inherently trouble-free. Recommended when instrument air or sweet and dry well gas is available, The AD Series is reliable and cost-effective. We can provide double fail-close and fail-open types.

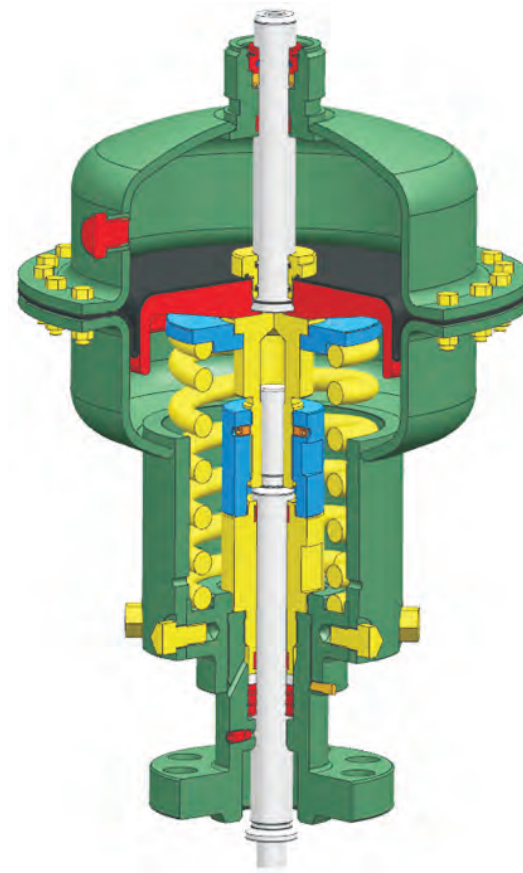

Additional features include

- Over-Pressure Protection: This actuator come equipped with pressure relief devices to protect personnel and guard against damage to the actuator in case of an overpressure condition.
- Corrosion Protection: The actuator housings and all internal components are coated to prevent corrosion due to environmental conditions and control pressure source.
- Backseat & backseat detection: This actuator come equipped with backseat and backseat detection hole.
- Maintenance: The actuators are lightweight and designed for ease of maintenance. All non-metallic seals and other quick-wear parts are easily replaceable.
- Packing Integrity: A tattletale weep port is located above the packing to provide visual confirmation of stem seal integrity during operation.
- Preset drift: Factory preset drift eliminates the need for field adjustments.

Available Sizes

MODEL	SIZE	STROKE
AD10	10"	UP TO 2-1/16" BORE
AD12	12"	UP TO 3-1/8" BORE
AD15	15"	UP TO 4-1/16" BORE
AD18	18"	UP TO 4-1/16" BORE
AD20	20"	UP TO 7-1/16" BORE

Dimensional Data

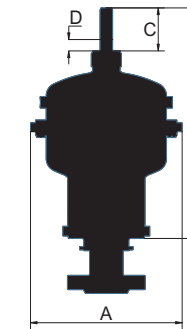

Valve Size	W.P.	Actuator Size	A		B		C		D		Weight		Swept Volume	
			Inch	MM	Inch	MM	Inch	MM	Inch	MM	LB	KG	in³	cm³
2-1/16	3,000	AD10	Ø12.99	Ø330	21.06	535	3.44	87.5	0.88	22.5	156	71	237	3,900
2-1/16	3,000	AD12	Ø15.12	Ø384	21.57	548	3.44	87.5	0.88	22.5	187	85	445	7,300
2-9/16	3,000	AD12	Ø15.12	Ø384	22.09	561	3.96	100.5	0.88	22.5	187	85	445	7,300
2-9/16	3,000	AD15	Ø18.31	Ø465	23.21	589.5	3.96	100.5	0.88	22.5	248	113	885	14,500
3-1/8	3,000	AD12	Ø15.12	Ø384	22.56	573	4.43	112.5	0.88	22.5	187	85	445	7,300
3-1/8	3,000	AD15	Ø18.31	Ø465	23.68	601.5	4.43	112.5	0.88	22.5	248	113	885	14,500
3-1/8	3,000	AD18	Ø21.06	Ø535	24.43	620.5	4.43	112.5	0.88	22.5	314	143	1,281	21,000
4-1/16	3,000	AD15	Ø18.31	Ø465	25.57	649.5	5.53	140.5	0.88	22.5	253	115	885	14,500
4-1/16	3,000	AD18	Ø21.06	Ø535	26.12	663.5	5.53	140.5	0.88	22.5	323	147	1,281	21,000
4-1/16	3,000	AD20-a	Ø23.43	Ø595	27.17	690	5.53	140.5	0.88	22.5	367	167	1,586	26,000
5-1/8	3,000	AD20-b	Ø23.43	Ø595	28.43	722	6.79	172.5	0.88	22.5	396	180	1,952	32,000
7-1/16	3,000	AD20-c	Ø23.43	Ø595	30.47	774	8.84	224.5	0.88	22.5	557	253	2,746	45,000
2-1/16	5,000	AD10	Ø12.99	Ø330	21.06	535	3.44	87.5	0.88	22.5	156	71	237	3,900
2-1/16	5,000	AD12	Ø15.12	Ø384	21.57	548	3.44	87.5	0.88	22.5	187	85	445	7,300
2-9/16	5,000	AD12	Ø15.12	Ø384	22.09	561	3.96	100.5	0.88	22.5	187	85	445	7,300
2-9/16	5,000	AD15	Ø18.31	Ø465	23.21	589.5	3.96	100.5	0.88	22.5	248	113	885	14,500
3-1/8	5,000	AD15	Ø18.31	Ø465	23.68	601.5	4.43	112.5	0.88	22.5	248	113	885	14,500
3-1/8	5,000	AD18	Ø21.06	Ø535	24.43	620.5	4.43	112.5	0.88	22.5	314	143	1,281	21,000
4-1/16	5,000	AD15	Ø18.31	Ø465	25.57	649.5	5.53	140.5	0.88	22.5	253	115	885	14,500
4-1/16	5,000	AD18	Ø21.06	Ø535	26.12	663.5	5.53	140.5	0.88	22.5	323	147	1,281	21,000
4-1/16	5,000	AD20-a	Ø23.43	Ø595	27.17	690	5.53	140.5	0.88	22.5	367	167	1,586	26,000
5-1/8	5,000	AD20-b	Ø23.43	Ø595	28.43	722	6.79	172.5	0.88	22.5	396	180	1,952	32,000
1-13/16	10,000	AD15	Ø18.31	Ø465	22.50	571.5	3.25	82.5	0.88	22.5	248	113	885	14,500
1-13/16	10,000	AD18	Ø21.06	Ø535	23.25	590.5	3.25	82.5	0.88	22.5	314	143	1,281	21,000
2-1/16	10,000	AD15	Ø18.31	Ø465	22.70	576.5	3.44	87.5	0.88	22.5	248	113	885	14,500
2-1/16	10,000	AD18	Ø21.06	Ø535	23.44	595.5	3.44	87.5	0.88	22.5	321	146	1,281	21,000
2-1/16	10,000	AD20-a	Ø23.43	Ø595	24.49	622	3.44	87.5	0.88	22.5	365	166	1,586	26,000
2-9/16	10,000	AD15	Ø18.31	Ø465	23.21	589.5	3.96	100.5	0.88	22.5	248	113	885	14,500
2-9/16	10,000	AD18	Ø21.06	Ø535	23.96	608.5	3.96	100.5	0.88	22.5	326	148	1,281	21,000
2-9/16	10,000	AD20-a	Ø23.43	Ø595	25.00	635	3.96	100.5	0.88	22.5	370	168	1,586	26,000
3-1/16	10,000	AD18	Ø21.06	Ø535	24.43	620.5	4.43	112.5	0.88	22.5	335	152	1,281	21,000
3-1/16	10,000	AD20-a	Ø23.43	Ø595	25.47	647	4.43	112.5	0.88	22.5	378	172	1,586	26,000
1-13/16	15,000	AD18	Ø21.06	Ø535	23.25	590.5	3.25	82.5	0.88	22.5	319	145	1,281	21,000
1-13/16	15,000	AD20-a	Ø23.43	Ø595	24.29	617	3.25	82.5	0.88	22.5	363	165	1,586	26,000
2-1/16	15,000	AD18	Ø21.06	Ø535	23.44	595.5	3.44	87.5	0.88	22.5	314	149	1,281	21,000
2-1/16	15,000	AD20-a	Ø23.43	Ø595	24.49	622	3.44	87.5	0.88	22.5	372	169	1,586	26,000
2-9/16	15,000	AD18	Ø23.43	Ø535	23.96	608.5	3.96	100.5	0.88	22.5	330	150	1,281	21,000
2-9/16	15,000	AD20-a	Ø23.43	Ø595	25.00	635	3.96	100.5	0.88	22.5	374	170	1,586	26,000

Control Pressure Chart

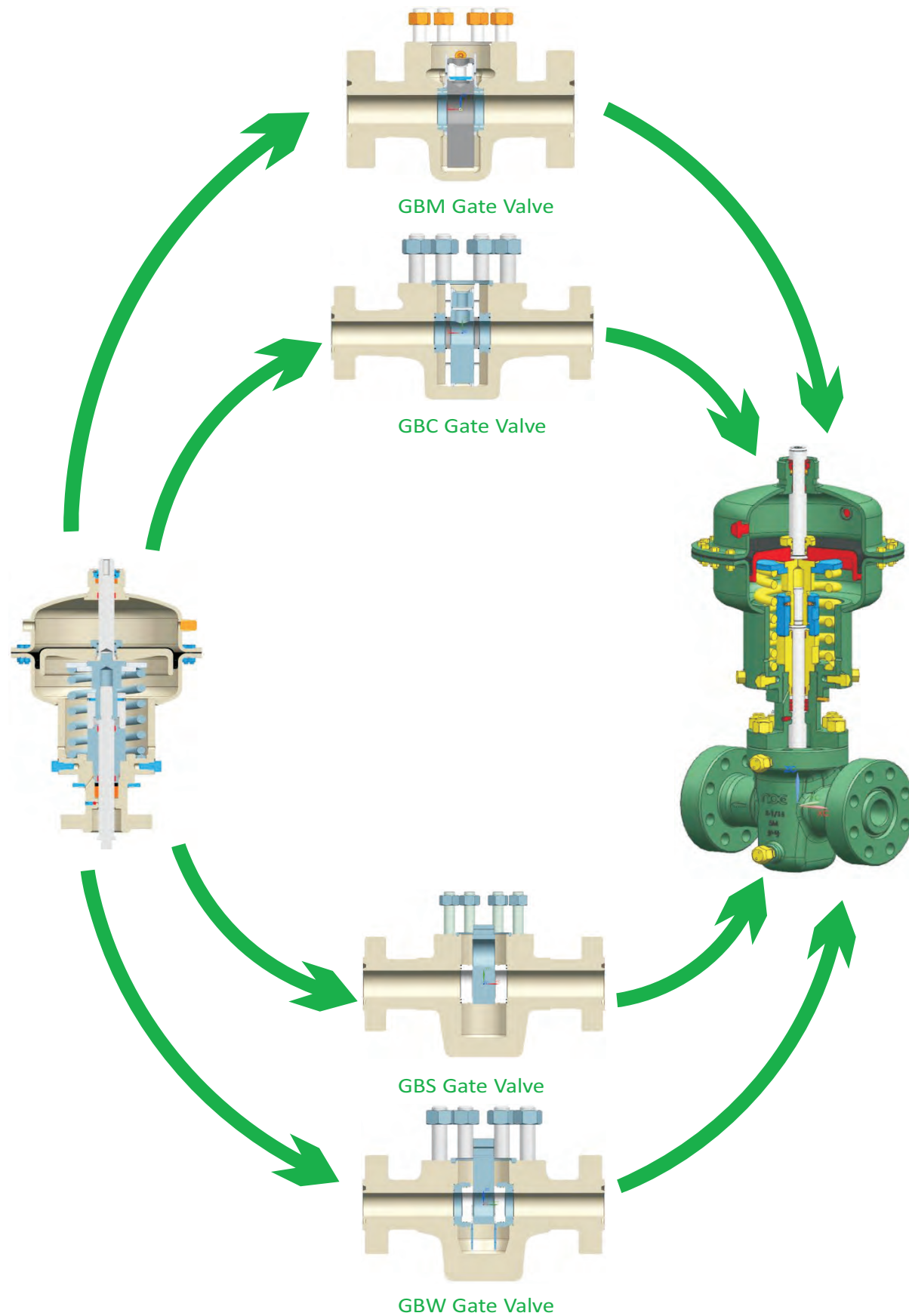

VALVE Bore	VALVE Working Pressure	ACTUATOR MODEL									
		AD10		AD12		AD15		AD18		AD20	
Size	Pressure	Equation	psi	Equation	psi	Equation	psi	Equation	psi	Equation	psi
2-1/16	3,000	0.025xWP+8	83	0.017xWP+6	57						
2-9/16	3,000			0.024xWP+6	78	0.014xWP+3	45				
3-1/8	3,000			0.034xWP+6	108	0.021xWP+3	63	0.015xWP+2	47		
4-1/16	3,000					0.031xWP+3	96	0.021xWP+3	66	0.017xWP+2	53
5-1/8	3,000									0.028xWP+2	86
7-1/16	3,000									0.049xWP+2	149
Contact Neway for Other Options / A single diaphragm actuator will not be sufficient											
2-1/16	5,000	0.025xWP+8	133	0.017xWP+6	91						
2-9/16	5,000			0.024xWP+6	126	0.014xWP+3	73				
3-1/8	5,000					0.021xWP+3	108	0.014xWP+2	72		
4-1/16	5,000					0.031xWP+3	158	0.021xWP+2	107	0.017xWP+2	87
5-1/8	5,000									0.028xWP+2	142
7-1/16	5,000	Contact Neway for Other Options / A single diaphragm actuator will not be sufficient									
1-13/16	10,000					0.011xWP+3	113	0.008xWP+2	82		
2-1/16	10,000					0.012xWP+3	123	0.009xWP+2	92	0.007xWP+2	72
2-9/16	10,000					0.014xWP+3	143	0.01xWP+2	102	0.008xWP+2	82
3-1/16	10,000							0.014xWP+2	142	0.011xWP+2	112
4-1/16	10,000	Contact Neway for Other Options / A single diaphragm actuator will not be sufficient									
5-1/8	10,000	Contact Neway for Other Options / A single diaphragm actuator will not be sufficient									
7-1/16	10,000	Contact Neway for Other Options / A single diaphragm actuator will not be sufficient									
1-13/16	15,000							0.008xWP+2	122	0.006xWP+2	92
2-1/16	15,000							0.009xWP+3	137	0.007xWP+2	107
2-9/16	15,000							0.01xWP+2	152	0.008xWP+2	122
3-1/16	15,000	Contact Neway for Other Options / A single diaphragm actuator will not be sufficient									
4-1/16	15,000	Contact Neway for Other Options / A single diaphragm actuator will not be sufficient									
5-1/8	15,000	Contact Neway for Other Options / A single diaphragm actuator will not be sufficient									
7-1/16	15,000	Contact Neway for Other Options / A single diaphragm actuator will not be sufficient									

Specifications for Standard Diaphragm Actuator			
API Temperature Rating	p	-20°F to +180°F	-29°C to +82°C
API Material Class		BB	
Maximum Operating Control Pressure		170 psi	
Maximum Test Pressure		255 psi	
Pressure Relief Valve		SET @ 170 psi	

Specification for Standard Actuator Bonnet						
Pressure Ratings	PAI 6A 3,000# PSI thru 15,000# PSI					
Sizes	API 6A 1-13/16" thru 7-1/16"					
Material Class	Non Nace / Non Sour Service					
	AA		BB		CC	
	Sour Service Nace Mr0175 Trim					
	DD-0,5	DD-1,5	DD-NL	EE-0,5	EE-1,5	EE-NL
	FF-0,5	FF-1,5	FF-NL	HH-0,5	HH-1,5	HH-NL
Product Specification Level	PSL 1, 2, 3,3G, 4					
Temperature Rating	L(-50°F) to (+350°F) (-46°C to +177°C)					

AP Actuator Introduction

NOE's AP pneumatic piston actuators are designed to be used with most manufacturers' gate valves. The simple design and operating principle make these actuators inherently trouble-free. Recommended when instrument air, sweet well gas, or sour well gas is available, The AP Series offers a reliable and cost effective option when robust actuator is required.

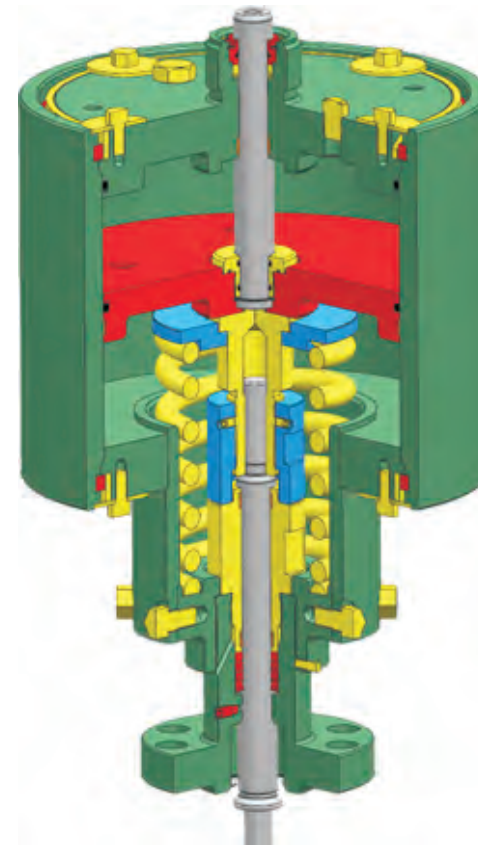

Additional features include

- Over-Pressure Protection: This actuator come equipped with pressure relief devices to protect personnel and guard against damage to the actuator in case of an overpressure condition.
- Corrosion Protection: The actuator housings and all internal components are coated to prevent corrosion due to environmental conditions and control pressure source.
- Backseat & backseat detection: This actuator come equipped with backseat and backseat detection hole.
- Maintenance: Easily removable piston allows for quick seal inspection and replacement.
- Packing Integrity: A tattletale weep port is located above the packing to provide visual confirmation of stem seal integrity during operation.
- Preset drift: Factory preset drift eliminates the need for field adjustments.

Available Sizes

MODEL	SIZE	STROKE
AP13	13"	UP TO 4-1/16" BORE
AP18	18"	UP TO 7-1/16" BORE
AP20	20"	UP TO 7-1/16" BORE

Dimensional Data

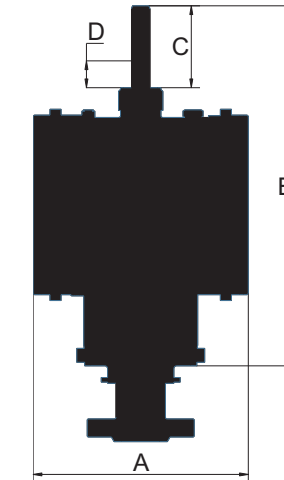

Valve Size	W.P.	Actuator Size	A		B		C		D		Weight		Swept Volume	
			Inch	MM	Inch	MM	Inch	MM	Inch	MM	LB	KG	in ³	cm ³
2-1/16	3,000	AP13-a	Ø14.57	Ø370	22.09	561	3.31	84	0.75	19	358.6	163	403	6600
2-9/16	3,000	AP13-b	Ø14.57	Ø370	23.11	587	3.82	97	0.75	19	369.6	168	470	7700
3-1/8	3,000	AP13-c	Ø14.57	Ø370	24.41	620	4.29	109	0.75	19	385	175	533	8730
4-1/16	3,000	AP13-d	Ø14.57	Ø370	27.05	687	5.39	137	0.75	19	413.6	188	679	11126
5-1/8	3,000	AP18-e	Ø19.68	Ø500	29.57	751	6.65	169	0.75	19	682	310	1652	27074
7-1/16	3,000	AP18-f	Ø19.68	Ø500	33.86	860	8.70	221	0.75	19	924	420	2243	36756
7-1/16	3,000	AP20-e	Ø21.85	Ø555	33.86	860	8.70	221	0.75	19	1430	650	2769	45377
2-1/16	5,000	AP13-a	Ø14.57	Ø370	22.09	561	3.31	84	0.75	19	358.6	163	403	6600
2-9/16	5,000	AP13-b	Ø14.57	Ø370	23.11	587	3.82	97	0.75	19	369.6	168	470	7700
3-1/8	5,000	AP13-c	Ø14.57	Ø370	24.41	620	4.29	109	0.75	19	385	175	533	8730
3-1/8	5,000	AP18-c	Ø19.68	Ø500	24.41	620	4.29	109	0.75	19	594	270	1081	17722
4-1/16	5,000	AP18-d	Ø19.68	Ø500	27.05	687	5.39	137	0.75	19	638	290	1332	21825
4-1/16	5,000	AP20-c	Ø21.85	Ø555	27.05	687	5.39	137	0.75	19	814	370	1607	26335
5-1/8	5,000	AP18-e	Ø19.68	Ø500	29.57	751	6.65	169	0.75	19	682	310	1652	27074
5-1/8	5,000	AP20-d	Ø21.85	Ø555	29.57	751	6.65	169	0.75	19	902	410	2040	33426
1-13/16	10,000	AP13-a	Ø14.57	Ø370	21.69	551	3.11	79	0.75	19	358.6	163	403	6600
1-13/16	10,000	AP18-a	Ø19.68	Ø500	21.69	551	3.11	79	0.75	19	572	260	771	12635
2-1/16	10,000	AP13-a	Ø14.57	Ø370	22.09	561	3.31	84	0.75	19	358.6	163	403	6600
2-1/16	10,000	AP18-a	Ø19.68	Ø500	22.09	561	3.31	84	0.75	19	594	270	771	12635
2-9/16	10,000	AP18-b	Ø19.68	Ø500	23.11	587	3.82	97	0.75	19	598.4	272	901	14768
3-1/16	10,000	AP18-c	Ø19.68	Ø500	24.41	620	4.29	109	0.75	19	616	280	1081	17722
3-1/16	10,000	AP20-b	Ø21.85	Ø555	24.41	620	4.29	109	0.75	19	770	350	1335	21878
4-1/16	10,000	AP20-c	Ø21.85	Ø555	27.05	687	5.39	137	0.75	19	880	400	1607	26335
1-13/16	15,000	AP18-a	Ø19.68	Ø500	21.69	551	3.11	79	0.75	19	594	270	771	12635
2-1/16	15,000	AP18-a	Ø19.68	Ø500	22.09	561	3.31	84	0.75	19	598.4	272	771	12635
2-9/16	15,000	AP18-b	Ø19.68	Ø500	23.11	587	3.82	97	0.75	19	631.4	287	901	14768
2-9/16	15,000	AP20-a	Ø21.85	Ø555	23.11	587	3.82	97	0.75	19	759	345	1112	18232
3-1/16	15,000	AP20-b	Ø21.85	Ø555	24.41	620	4.29	109	0.75	19	792	360	1335	21878

Control Pressure Chart

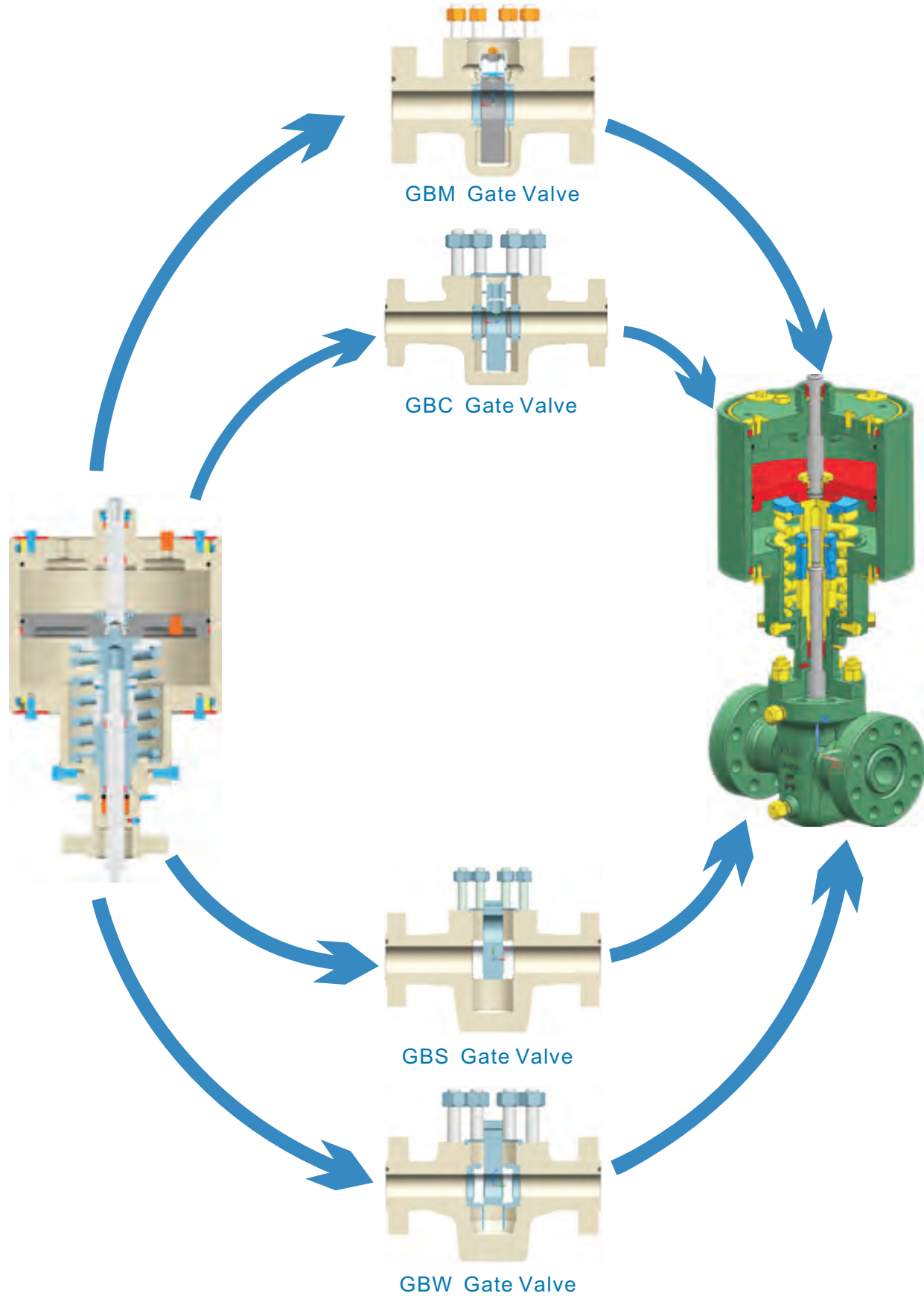

VALVE Bore	VALVE Working Pressure	ACTUATOR MODEL					
		AP13		AP18		AP20	
Size	Pressure	Equation	psi	Equation	psi	Equation	psi
2-1/16	3,000	0.012xWP+3	39				
2-9/16	3,000	0.017xWP+3	54				
3-1/8	3,000	0.024xWP+4	76				
4-1/16	3,000	0.036xWP+4	112				
5-1/8	3,000			0.03xWP+2	93		
7-1/16	3,000			0.054xWP+2	164	0.044xWP+3	135
5,000 psi							
2-1/16	5,000	0.012xWP+3	63				
2-9/16	5,000	0.017xWP+3	88				
3-1/8	5,000	0.024xWP+4	124	0.012xWP+3	63		
4-1/16	5,000			0.019xWP+2	97	0.015xWP+2	78
5-1/8	5,000			0.03xWP+2	152	0.024xWP+3	123
7-1/16	5,000	Contact Neway for Other Options / A single pneumatic piston actuator will not be sufficient					
10,000 psi							
1-13/16	10,000	0.013xWP+3	134	0.007xWP+2	72		
2-1/16	10,000	0.014xWP+3	143	0.008xWP+2	82		
2-9/16	10,000			0.009xWP+2	92		
3-1/16	10,000			0.03xWP+2	122	0.01xWP+2	103
4-1/16	10,000					0.015xWP+2	153
5-1/8	10,000	Contact Neway for Other Options / A single pneumatic piston actuator will not be sufficient					
7-1/16	10,000	Contact Neway for Other Options / A single pneumatic piston actuator will not be sufficient					
15,000 psi							
1-13/16	15,000			0.007xWP+2	107		
2-1/16	15,000			0.008xWP+2	122		
2-9/16	15,000			0.009xWP+2	137	0.007xWP+2	107
3-1/16	15,000					0.01xWP+3	153
4-1/16	15,000	Contact Neway for Other Options / A single pneumatic piston actuator will not be sufficient					
5-1/8	15,000	Contact Neway for Other Options / A single pneumatic piston actuator will not be sufficient					
7-1/16	15,000	Contact Neway for Other Options / A single pneumatic piston actuator will not be sufficient					

Specifications for Standard Pneumatic Piston Actuator			
API Temperature Rating	p	-20°F to +180°F	-29°C to +82°C
API Material Class		BB	
Maximum Operating Control Pressure		170 psi	
Maximum Test Pressure		255 psi	
Pressure Relief Valve		SET @ 170 psi	

Specifications for Standard Pneumatic Piston Actuator						
Pressure Ratings	PAI 6A 3,000# PSI thru 15,000# PSI					
Sizes	API 6A 1-13/16" thru 7-1/16"					
Material Class	Non Nace / Non Sour Service					
	AA		BB		CC	
	Sour Service Nace Mr0175 Trim					
	DD-0,5	DD-1,5	DD-NL	EE-0,5	EE-1,5	EE-NL
	FF-0,5	FF-1,5	FF-NL	HH-0,5	HH-1,5	HH-NL
Product Specification Level	PSL 1, 2,3, 3G, 4					
Temperature Rating	L(-50°F) to (+350°F) (-46°C to +177°C)					

AH Actuator Introduction

NOE's AH hydraulic actuators are designed to be used with most manufacturers' gate valves. Like our pneumatic actuators, the simple design of the AH Series actuators make them inherently trouble-free. Recommended for high-thrust applications required for large-bore and high-pressure valves-when there is no gas source or when the well gas is too sour, the AH Series offers a reliable and robust actuator that can be installed in harsh and remote environments.

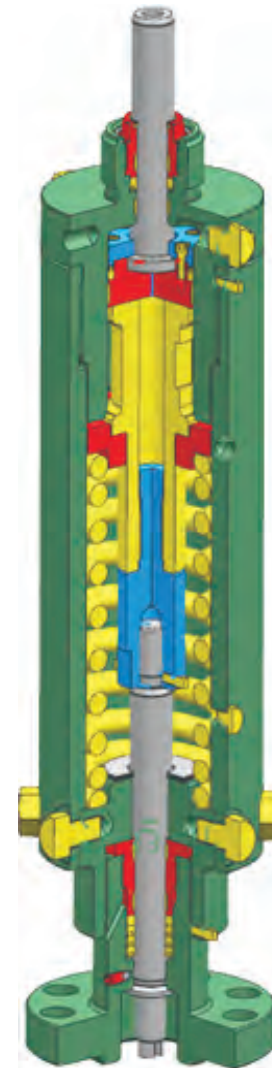

Additional features include

- **Over-Pressure Protection:** This actuator come equipped with pressure relief devices to protect personnel and guard against damage to the actuator in case of an over pressure condition. The pressure relief device is easily inspected and is field-replaceable.
- **Corrosion Protection:** The actuator housings are internally and externally coated to prevent corrosion due to environmental conditions. All internal components are either stainless steel or are coated to prevent corrosion due to any contamination that might be present in the control pressure source.
- **Backseat & backseat detection:** This actuator come equipped with backseat and backseat and backseat detection hole.
- **Maintenance:** The actuators are designed for ease of maintenance. All non-metallic seals and other parts are easily replaceable.
- **Packing Integrity:** A tattletale weep port is located above the packing to provide visual confirmation of stem seal integrity during operation.
- **Preset drift:** Factory preset drift eliminates the need for field adjustments.

Available Sizes

MODEL	SIZE	STROKE
AH35	3.5"	UP TO 4-1/16" BORE
AH45	4.5"	UP TO 5-1/8" BORE
AH65	6.5"	UP TO 7-1/16" BORE
AH95	9.5"	UP TO 7-1/16" BORE
AH110	11"	UP TO 7-1/16" BORE

Dimensional Data

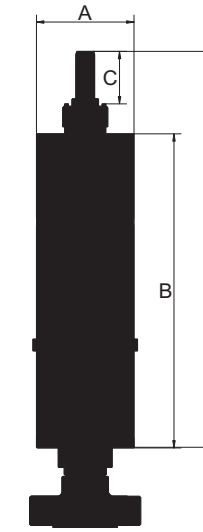

Valve Size	W.P.	Actuator Size	A		B		C		D		Weight		Swept	
			Inch	MM	Inch	MM	Inch	MM	Inch	MM	LB	KG	in ³	cm ³
2-1/16	3,000	AH35	Ø6.5	Ø165	20	510	3.2	81	25.6	650	173	78.6	26.5	434
2-9/16	3,000	AH35	Ø6.5	Ø165	20.5	520	3.7	94	26.6	676	191	87	29	476
3-1/8"	3,000	AH35	Ø6.5	Ø165	21	535	4.17	106	27.6	700	202	92	31	508
3-1/8"	3,000	AH45	Ø8.6	Ø219	21	535	4.17	106	27.6	700	328	149	48	793
4-1/16	3,000	AH35	Ø6.5	Ø165	22.2	563	5.27	134	29.8	756	253	115	39	639
4-1/16	3,000	AH45	Ø8.6	Ø219	22.2	563	5.27	134	29.8	756	365	166	62	1013
5-1/8	3,000	AH45	Ø8.6	Ø219	23.4	595	6.5	166	32.3	820	383	174	75	1233
5-1/8	3,000	AH65	Ø11.4	Ø290	23.4	595	6.5	166	32.3	820	660	300	186	3049
7-1/16	3,000	AH65	Ø11.4	Ø290	25.5	647	8.6	218	36.4	924	770	350	253	4147
2-1/16	5,000	AH35	Ø6.5	Ø165	20	510	3.2	81	25.6	650	173	78.6	26.5	434
2-9/16	5,000	AH35	Ø6.5	Ø165	20.5	520	3.7	94	26.6	676	191	87	29	476
3-1/8"	5,000	AH35	Ø6.5	Ø165	21	535	4.17	106	27.6	700	202	92	31	508
3-1/8"	5,000	AH45	Ø8.6	Ø219	21	535	4.17	106	27.6	700	328	149	48	793
4-1/16	5,000	AH45	Ø8.6	Ø219	22.2	563	5.27	134	29.8	756	365	166	62	1013
5-1/8	5,000	AH65	Ø11.4	Ø290	23.4	595	6.5	166	32.3	820	660	300	186	3049
7-1/16	5,000	AH65	Ø11.4	Ø290	25.5	647	8.6	218	36.4	924	770	350	253	4147
7-1/16	5,000	AH95	Ø15.3	Ø390	25.5	647	8.6	218	36.4	924	1210	550	682	11176
1-13/16	10,000	AH35	Ø6.5	Ø165	20	510	3	76	25.4	645	176	80	26.5	434
1-13/16	10,000	AH45	Ø8.6	Ø219	20	510	3	76	25.4	645	321	146	36	587
2-1/16	10,000	AH35	Ø6.5	Ø165	20	510	3.2	81	25.6	650	189	86	26.5	434
2-1/16	10,000	AH45	Ø8.6	Ø219	20	510	3.2	81	25.6	650	330	150	36	587
2-9/16	10,000	AH45	Ø8.6	Ø219	20.5	520	3.7	94	26.6	676	343	156	48	793
3-1/16	10,000	AH45	Ø8.6	Ø219	21	535	4.17	106	27.6	700	359	163	48	793
4-1/16	10,000	AH65	Ø11.4	Ø290	22.2	563	5.27	134	29.8	756	684	311	150	2459
5-1/8	10,000	AH65	Ø11.4	Ø290	23.4	595	6.5	166	32.3	820	741	337	186	3049
7-1/16	10,000	AH95	Ø15.3	Ø390	25.5	647	8.6	218	36.4	924	1234	561	682	11176
1-13/16	15,000	AH45	Ø8.6	Ø219	20	510	3	76	25.4	645	341	155	36	587
2-1/16	15,000	AH45	Ø8.6	Ø219	20	510	3.2	81	25.6	650	341	155	36	587
2-9/16	15,000	AH45	Ø8.6	Ø219	20.5	520	3.7	94	26.6	676	378	172	48	793
3-1/16	15,000	AH65	Ø11.4	Ø290	21	535	4.17	106	27.6	700	700	318	128	2100
4-1/16	15,000	AH65	Ø11.4	Ø290	22.2	563	5.27	134	29.8	756	706	321	150	2459
5-1/8	15,000	AH95	Ø15.3	Ø390	23.4	595	6.5	166	32.3	820	1142	519	518	8500
5-1/8	15,000	AH110	Ø19.3	Ø490	23.4	595	6.5	166	37.4	950	1390	632	687	11256
7-1/16	15,000	AH110	Ø19.3	Ø490	25.5	647	8.6	218	45.3	1150	1459	663	869	14236

Control Pressure Chart

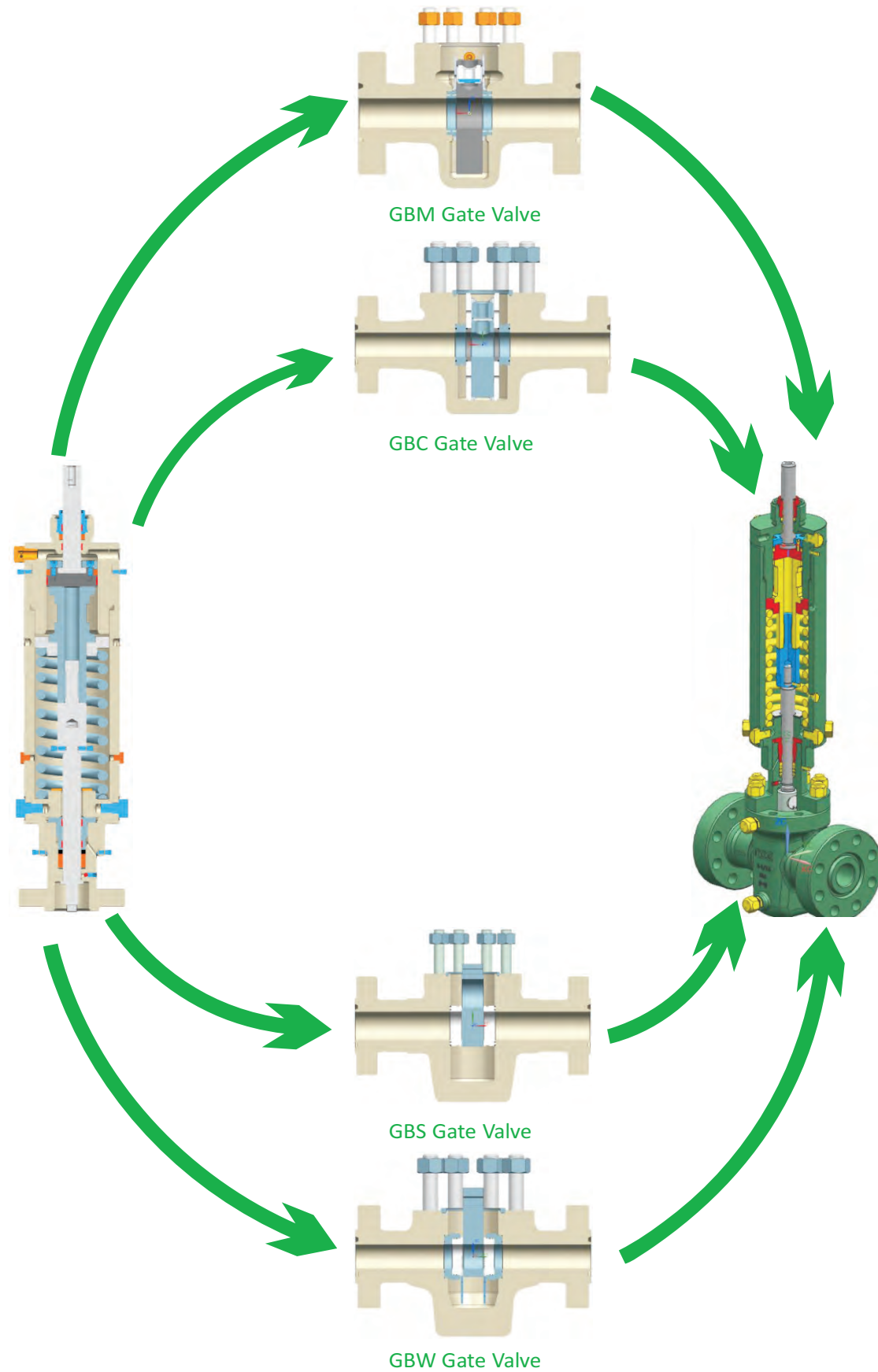

VALVE	VALVE	ACTUATOR MODEL									
		AH35		AH45		AH65		AH95		AH110	
Bore	Working Pressure	Equation	psi	Equation	psi	Equation	psi	Equation	psi	Equation	psi
2-1/16	3,000	0.202xWP+60	666								
2-9/16	3,000	0.264xWP+59	851								
3-1/8	3,000	0.378xWP+59	1193	0.216xWP+119	767						
4-1/16	3,000	0.564xWP+59	1751	0.322xWP+119	1085						
5-1/8	3,000			0.521xWP+119	1662	0.239xWP+63	780				
7-1/16	3,000					0.428xWP+63	1348				
2-1/16	5,000	0.202xWP+60	1070								
2-9/16	5,000	0.264xWP+59	1379								
3-1/8	5,000	0.378xWP+59	1949	0.216xWP+119	1199						
4-1/16	5,000			0.322xWP+119	1729						
5-1/8	5,000					0.148xWP+63	1258				
7-1/16	5,000					0.239xWP+63	2203	0.197xWP+43	1026		
1-13/16	10,000	0.205xWP+59	2109	0.116xWP+119	1279						
2-1/16	10,000	0.227xWP+59	2329	0.13xWP+119	1419						
2-9/16	10,000			0.151xWP+119	1629						
3-1/16	10,000			0.213xWP+119	2249						
4-1/16	10,000					0.148xWP+63	1543				
5-1/8	10,000					0.239xWP+63	2453				
7-1/16	10,000							0.197xWP+43	2008		
1-13/16	15,000			0.116xWP+119	1859						
2-1/16	15,000			0.13xWP+119	2069						
2-9/16	15,000			0.151xWP+119	2384						
3-1/16	15,000					0.126xWP+63	1953				
4-1/16	15,000					0.148xWP+63	2283				
5-1/8	15,000							0.153xWP+29	2324	0.108xWP+21	1641
7-1/16	15,000									0.191xWP+21	2886

Specifications for Standard Hydraulic Actuator			
API Temperature Rating	L	-50°F to +180°F	-46°C to +82°C
API Material Class	AA/BB/CC		
Maximum Operating Control Pressure	3000 psi		
Maximum Test Pressure	4500 psi		
Pressure Relief Valve	SET @ 3000 psi		

Specifications for Standard Pneumatic Piston Actuator						
Pressure Ratings	PAI 6A 3,000# PSI thru 15,000# PSI					
Sizes	API 6A 1-13/16" thru 7-1/16"					
Material Class	Non Nace / Non Sour Service					
	AA		BB		CC	
	Sour Service Nace Mr0175 Trim					
	DD-0,5	DD-1,5	DD-NL	EE-0,5	EE-1,5	EE-NL
	FF-0,5	FF-1,5	FF-NL	HH-0,5	HH-1,5	HH-NL
Product Specification Level	PSL 1, 2,3, 3G, 4					
Temperature Rating	L(-50°F) to (+350°F) (-46°C to +177°C)					

AC Actuator Introduction

NOE's AC hydraulic actuators are designed to be used with most manufacturers' gate valves. Like our AD/AP/AH actuators, the simple design of the AH Series actuators make them inherently trouble-free. Recommended for high-thrust applications required for large-bore and high-pressure valves-when there is no gas source or when the well gas is too sour, the AC Series offers an another reliable and robust actuator that can be installed in harsh and remote environments.

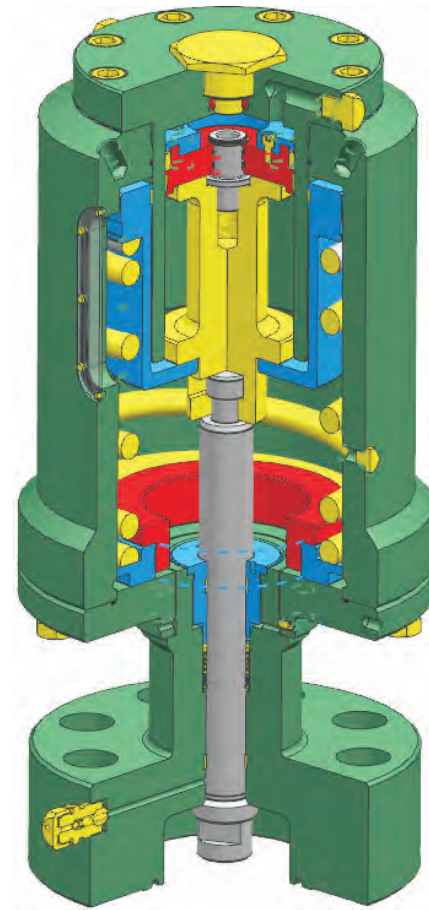

Additional features include

- Quick disconnect mechanism: The AC SSV assembly is designed such that the actuator can be removed from the gate valve as a separate assembly with the valve in service. This quick disconnect mechanism for the actuator allows fast removal without disturbing the body/bonnet connection, and this provides immediate access to stem packing.
- Over-Pressure Protection: This actuator come equipped with pressure relief devices to protect personnel and guard against damage to the actuator in case of an over pressure condition. The pressure relief device is easily inspected and is field-replaceable.
- Packing Integrity: A tattletale weep port is located above the packing to provide visual confirmation of stem seal integrity during operation.
- Maintenance: The actuator has single forged unitized top cap and cylinder for simple on-line maintenance.
- Preset drift: Factory preset drift eliminates the need for field adjustments.

Available Sizes

MODEL	SIZE	STROKE
AC45	4.5"	UP TO 5-1/8" BORE
AC58	5.875"	UP TO 7-1/16" BORE
AC65	6.5"	UP TO 7-1/16" BORE
AC95	9.5"	UP TO 7-1/16" BORE
AC110	11"	UP TO 7-1/16" BORE

Dimensional Data



Valve Size	W.P.	Actuator Size	A		B		Weight		Swept	
			Inch	MM	Inch	MM	LB	KG		
2-1/16	5,000	AC45	Contact Neway for more details						35	573
2-9/16	5,000	AC45	Contact Neway for more details						42	688
3-1/8"	5,000	AC45	Contact Neway for more details						48	793
3-1/8"	5,000	AC58	Ø13.38	Ø340	16.45	418	429	195	73	1200
4-1/16	5,000	AC45	Contact Neway for the details						62	1013
4-1/16	5,000	AC58	Ø13.38	Ø340	18.66	474	506	230	96	1573
5-1/8	5,000	AC65	Contact Neway for more details						186	3049
7-1/16	5,000	AC65	Contact Neway for more details						253	4147
7-1/16	5,000	AC95	Contact Neway for more details						682	11176
1-13/16	10,000	AC45	Contact Neway for more details						35.7	587
2-1/16	10,000	AC45	Contact Neway for more details						35.7	587
2-9/16	10,000	AC45	Contact Neway for more details						48	793
3-1/16	10,000	AC45	Contact Neway for more details						48	793
3-1/16	10,000	AC58	Ø13.38	Ø340	16.45	418	453	205.8	73	1200
4-1/16	10,000	AC58	Ø13.38	Ø340	18.66	474	551.5	250.7	196	1573
4-1/16	10,000	AC65	Contact Neway for more details						150	2459
5-1/8	10,000	AC65	Contact Neway for more details						186	3049
7-1/16	10,000	AC95	Contact Neway for more details						682	11176
1-13/16	15,000	AC45	Contact Neway for more details						35.7	587
2-1/16	15,000	AC45	Contact Neway for more details						35.7	587
2-9/16	15,000	AC45	Contact Neway for more details						48	793
2-9/16	15,000	AC58	Contact Neway for more details						63.3	1039
3-1/16	15,000	AC58	Ø13.38	Ø340	16.45	418	484	220	73	1200
3-1/16	15,000	AC65	Contact Neway for more details						128	2100
4-1/16	15,000	AC65	Contact Neway for more details						150	2459
5-1/8	15,000	AC95	Contact Neway for more details						518	8500
5-1/8	15,000	AC110	Contact Neway for more details						687	11256
7-1/16	15,000	AC110	Contact Neway for more details						869	14236

Control Pressure Chart

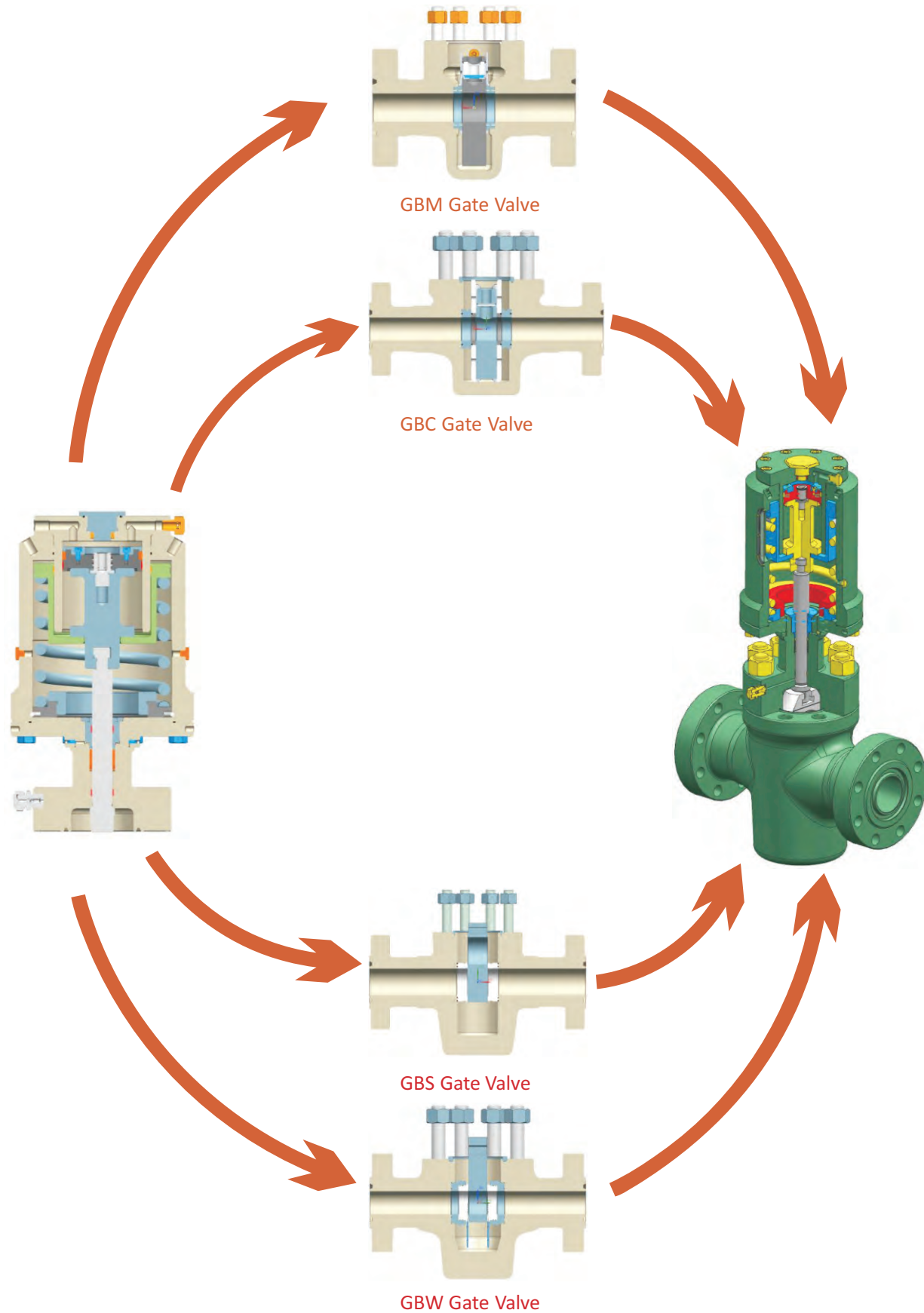

VALVE	VALVE	ACTUATOR MODEL									
		Bore	Working	AC45		AC58		AC65		AC95	
Size	Pressure	Equation	psi	Equation	psi	Equation	psi	Equation	psi	Equation	psi
2-1/16	5,000	0.13xWP+119	769								
2-9/16	5,000	0.153xWP+119	884								
3-1/8	5,000	0.216xWP+119	1199	0.163xWP+119	934						
4-1/16	5,000	0.322xWP+119	1729	0.23xWP+119	1269						
5-1/8	5,000					0.239xWP+63	1258				
7-1/16	5,000					0.426xWP+63	2203	0.197xWP+43	1026		
Separator											
1-13/16	10,000	0.116xWP+119	1279								
2-1/16	10,000	0.13xWP+119	1419								
2-9/16	10,000	0.151xWP+119	1629								
3-1/16	10,000	0.213xWP+119	2249	0.163xWP+119	1794						
4-1/16	10,000			0.191xWP+119	2029	0.148xWP+63	1543				
5-1/8	10,000					0.239xWP+63	2453				
7-1/16	10,000							0.197xWP+43	2008		
Separator											
1-13/16	15,000	0.116xWP+119	1859								
2-1/16	15,000	0.13xWP+119	2069								
2-9/16	15,000	0.151xWP+119	2384	0.13xWP+119	2069						
3-1/16	15,000			0.171xWP+119	2684	0.126xWP+63	1953				
4-1/16	15,000					0.148xWP+63	2283				
5-1/8	15,000							0.53xWP+29	2324	0.108xWP+21	1641
7-1/16	15,000									0.191xWP+21	2886

Specifications for Standard Hydraulic Actuator			
API Temperature Rating	L	-50°F to +180°F	-46°C to +82°C
API Material Class	AA/BB/CC		
Maximum Operating Control Pressure	3000 psi		
Maximum Test Pressure	4500 psi		
Pressure Relief Valve	SET @ 3000 psi		

Specifications for Standard Pneumatic Piston Actuator						
Pressure Ratings	PAI 6A 5,000# PSI thru 15,000# PSI					
Sizes	API 6A 1-13/16" thru 7-1/16"					
Material Class	Non Nace / Non Sour Service					
	AA	BB		CC		
	Sour Service Nace Mr0175 Trim					
	DD-0,5	DD-1,5	DD-NL	EE-0,5	EE-1,5	EE-NL
	FF-0,5	FF-1,5	FF-NL	HH-0,5	HH-1,5	HH-NL
Product Specification Level	PSL 1, 2, 3, 3G, 4					
Temperature Rating	L(-50°F) to (+350°F) (-46°C to +177°C)					

DH Actuator Introduction

NOE's DH hydraulic double acting actuators are designed to be used to open and close the slab gate valve. They are especially suitable for the gate location need to be fully hydraulic controlled. The actuators can be fitted to choke and kill systems, frac applications and other drilling operations.

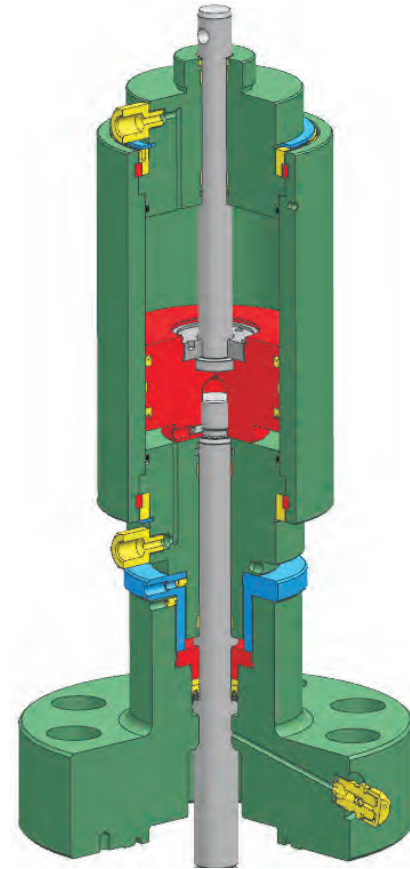

Additional features include

- Improved Corrosion Control: All non-stainless components are coated to provide resistance against the corrosive effect of harsh environments.
- Housing: The pressurized housing is designed as a protective member for the piston and stem. The design is symmetrical thereby simplifying assembly. A hard plated wear surface protects and ensures seal integrity.
- Ease of Maintenance: Top shaft can be replaced by removal of top fixer. To replace piston seal, remove piston from actuator housing. This concept provides easy removal and seal replacement.
- Longer Top Shaft Seal Life: The top shaft seals are T-seal designed for dynamic sealing applications. The top shaft seals are protected from dirt and debris by a PU rod wiper. These two design features guarantee a longer seal life requiring minimal maintenance.

Available Sizes

MODEL	SIZE	STROKE
DH35	3.5"	UP TO 4-1/16" BORE
DH45	4.5"	UP TO 5-1/8" BORE
DH65	6.5"	UP TO 7-1/16" BORE
DH90	9"	UP TO 7-1/16" BORE

Dimensional Data



Valve Size	W.P.	Actuator Size	A		B		Weight		Swept			
			Inch	MM	Inch	MM	LB	KG				
2-1/16	5,000	DH35	Contact Neway for more details								26.5	434
2-9/16	5,000	DH35	Contact Neway for more details								29	476
3-1/8"	5,000	DH35	Ø5.3	Ø135	15.75	400	224.4	102	31	508		
4-1/16	5,000	DH35	Contact Neway for more details								39	639
5-1/8	5,000	DH45	Contact Neway for more details								75	1233
7-1/16	5,000	DH65	Contact Neway for more details								253	4147
1-13/16	10,000	DH35	Contact Neway for more details								26.5	434
2-1/16	10,000	DH35	Contact Neway for more details								26.5	434
2-9/16	10,000	DH45	Ø6.61	Ø168	15.2	385	255.2	116	48	793		
3-1/16	10,000	DH45	Ø6.61	Ø168	15.75	400	270.6	123	48	793		
4-1/16	10,000	DH45	Ø6.61	Ø168	16.46	418	312.4	142	62	1013		
5-1/8	10,000	DH65	Ø8.62	Ø219	18.58	472	478	217.3	186	3049		
7-1/16	10,000	DH65	Ø8.62	Ø219	20	508	627	285	253	4147		
1-13/16	15,000	DH35	Contact Neway for more details								26.5	434
2-1/16	15,000	DH45	Ø6.61	Ø168	13.8	351	299.2	136	36	587		
2-9/16	15,000	DH45	Ø6.61	Ø168	15.2	385	334.4	152	48	793		
3-1/16	15,000	DH65	Ø8.62	Ø219	15.75	400	352	160	128	2100		
4-1/16	15,000	DH65	Ø8.62	Ø219	16.85	428	399.7	181.7	150	2459		
5-1/8	15,000	DH65	Ø8.62	Ø219	18.58	472	640.6	291.2	186	3049		
7-1/16	15,000	DH90	Ø10.75	Ø273	21.65	550	1232	560	563	9232		

Control Pressure Chart

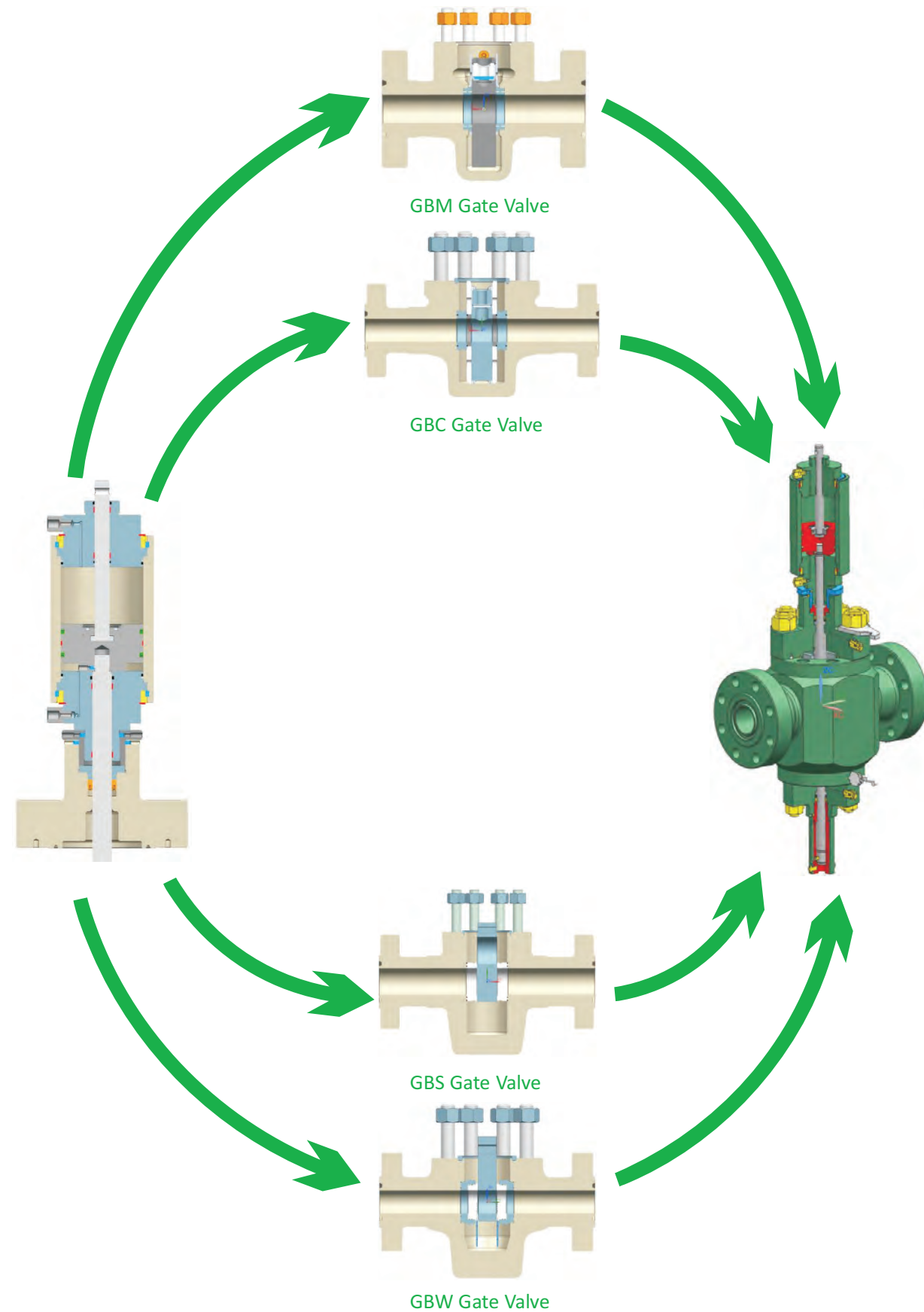

VALVE	VALVE	ACTUATOR MODEL							
		DH35		DH45		DH65		DH90	
Bore	Working Pressure	Equation	psi	Equation	psi	Equation	psi	Equation	psi
2-1/16	5,000	0.191xWP (close)	960						
		0.081xWP (open)	400						
2-9/16	5,000	0.211xWP (close)	1053						
		0.118xWP (open)	586						
3-1/8	5,000	0.26xWP (close)	1302						
		0.167xWP (open)	835						
4-1/16	5,000	0.423xWP (close)	2113						
		0.277xWP (open)	1383						
5-1/8	5,000			0.371xWP (close)	1856				
				0.251xWP (open)	1254				
7-1/16	5,000					0.343xWP (close)	1715		
						0.247xWP (open)	1235		
Separator									
1-13/16	10,000	0.166xWP (close)	1659						
		0.059xWP (open)	590						
2-1/16	10,000	0.191xWP (close)	1915						
		0.081xWP (open)	808						
2-9/16	10,000			0.136xWP (close)	1360				
				0.062xWP (open)	620				
3-1/16	10,000			0.213xWP (close)	2121				
				0.093xWP (open)	928				
4-1/16	10,000			0.242xWP (close)	2420				
				0.159xWP (open)	1586				
5-1/8	10,000					0.17xWP (close)	1705		
						0.115xWP (open)	1155		
7-1/16	10,000					0.282xWP (close)	2821		
						0.21xWP (open)	2070		
Separator									
1-13/16	15,000	0.166xWP (close)	2490						
		0.059xWP (open)	885						
2-1/16	15,000			0.115xWP (close)	1734				
				0.047xWP (open)	705				
2-9/16	15,000			0.151xWP (close)	2250				
				0.068xWP (open)	1010				
3-1/16	15,000					0.1xWP (close)	1500		
						0.056xWP (open)	840		
4-1/16	15,000					0.134xWP (close)	2022		
						0.103xWP (open)	1550		
5-1/8	15,000					0.171xWP (close)	2565		
						0.115xWP (open)	1730		
7-1/16	15,000							0.165xWP (close)	2470
								0.117xWP (open)	1765

NOTE:

- ① 4-1/16 to 7-1/16 are the Tailrod hydraulic gate valve (with balance stem on another side of the body).
- ② Open and close pressures show reflects the use of a direct acting slab gate. If a reverse acting slab gate is used, the open and close pressures need to be reversed.

Specifications for Standard Hydraulic Actuator			
API Temperature Rating	L	-50°F to +180°F	-46°C to +82°C
API Material Class	AA/BB/CC		
Maximum Operating Control Pressure	3000 psi		
Maximum Test Pressure	4500 psi		
Pressure Relief Valve	SET @ 3000 psi		

Specifications for Standard Pneumatic Piston Actuator						
Pressure Ratings	PAI 6A 5,000# PSI thru 15,000# PSI					
Sizes	API 6A 1-13/16" thru 7-1/16"					
	Non Nace / Non Sour Service					
Material Class	AA	BB		CC		
	Sour Service Nace Mr0175 Trim					
	DD-0,5	DD-1,5	DD-NL	EE-0,5	EE-1,5	EE-NL
	FF-0,5	FF-1,5	FF-NL	HH-0,5	HH-1,5	HH-NL
Product Specification Level	PSL 1, 2,3, 3G, 4					
Temperature Rating	L(-50°F) to (+350°F) (-46°C to +177°C)					

AD actuator Redress Kits

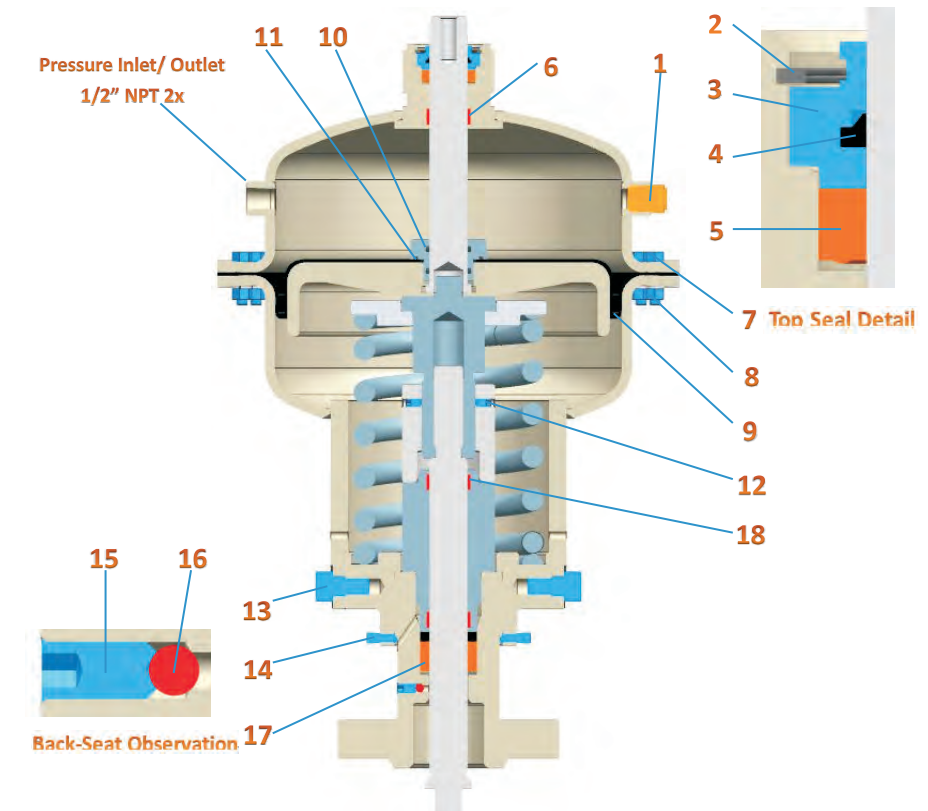

NOE stocks redress kits for all its actuator models. Kit contents are listed below for the three different redress kits available for the Model AD Actuator.

① Actuator Redress Kit Contents

#	Description	Qty
1	Pressure Relief Valve (See Note1)	1
2	Shaft Seal Spiral Retaining Ring	1
3	Shaft Seal Retainer	1
4	Rod Wiper	1
5	Upper Shaft Seal	1
6	Wear Band(1)	1
7	Housing Bolts (See Note2)	*
8	Housing Washers/Nuts (See Note2)	*
9	Diaphragm	1
10	O-Ring(1)	2
11	O-Ring(2)	1

② Actuator Attachment Kit Contents

#	Description	Qty
12	Set Screw(1)	4
13	Bolt	8
14	Set Screw(2)	2

③ Bonnet Redress Kit Contents

#	Description	Qty
15	Set Screw(3)	1
16	Ball	1
17	Packing Seal	3
18	Wear Band(2)	2

Note1: Pressure relief valve is set at 170 psi. Valve will relieve any pressure above 170 psi inside the upper housing and then automatically reset.

Note2: The number of housing bolts, washers and nuts depends on actuator model AD10 (24)/ AD12 (24)/ AD15 (32)/ AD18 (48)/ AD20 (60).

AP Actuator Redress Kits

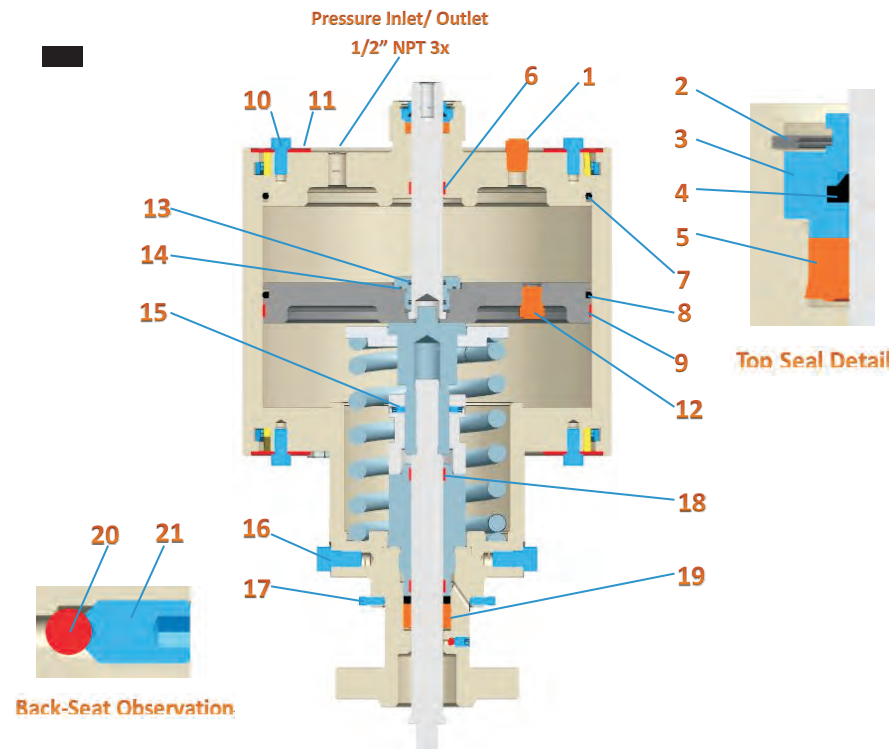

NOE stocks redress kits for all its actuator models. Kit contents are listed below for the three different redress kits available for the Model AP Actuator.

① Actuator Redress Kit Contents

#	Description	Qty
1	Pressure Relief Valve(1)(See Note1)	1
2	Shaft Seal Spiral Retaining Ring	1
3	Shaft Seal Retainer	1
4	Rod Wiper	1
5	Upper Shaft Seal	1
6	Wear Band(1)	1
7	Cylinder O-Ring	1
8	Piston O-Ring	1
9	Wear Band(2)	1
10	Cylinder Retaining Bolt	8
11	Cylinder Retaining Washer	8
12	Pressure Relief Valve(2) (See Note1)	1
13	O-Ring(1)	2
14	O-Ring(2)	1

② Actuator Attachment Kit Contents

#	Description	Qty
15	Set Screw(1)	4
16	Bolt	8
17	Set Screw(2)	2

③ Bonnet Redress Kit Contents

#	Description	Qty
18	Wear Band(2)	2
19	Packing Seal	3
20	Ball	1
21	Set Screw(3)	1

Note1: Pressure relief valve (1) is set at 170 psi. Valve will relieve any pressure above 170 psi inside the upper housing and then automatically reset. Pressure relief valve (2) is set at 225psi, and it provides a secondary protection when the pressure relief valve (1) failed.

AH Actuator Redress Kits

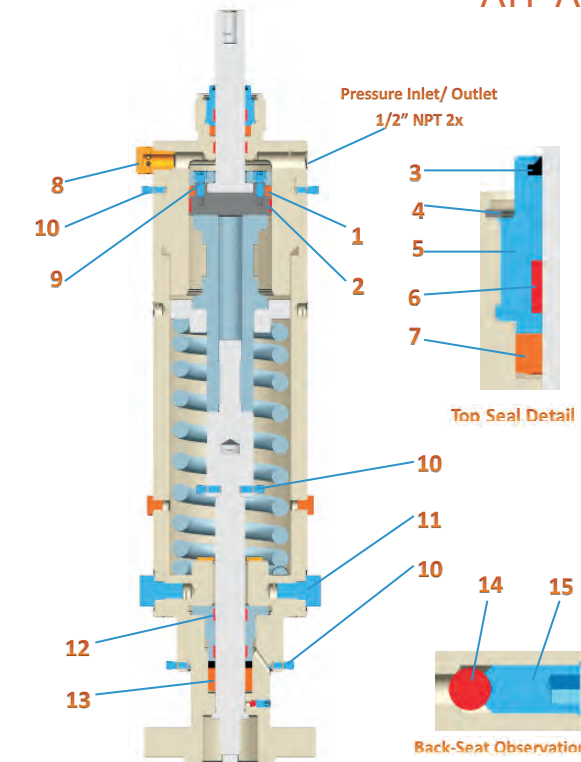

NOE stocks redress kits for all its actuator models. Kit contents are listed below for the three different redress kits available for the Model AH Actuator.

① Actuator Redress Kit Contents

#	Description	Qty
1	Piston Seal	1
2	Wear Band(1)	1
3	Rod Wiper	1
4	Shaft Seal Spiral Retaining Ring	1
5	Shaft Seal Retainer	1
6	Wear Band(2)	2
7	Upper Shaft Seal	1
8	Rupture Disc Assembly(See Note1)	1
9	Hexagon Socket Bolt(See Note2)	*

② Actuator Attachment Kit Contents

#	Description	Qty
10	Set Screw(1)	6
11	Bolt	8

③ Bonnet Redress Kit Contents

#	Description	Qty
12	Wear Band(3)	2
13	Packing Seal	3
14	Ball	1
15	Set Screw(2)	1

Note1: Rupture disc assembly is set at 3000 psi. Disc will rupture when hydraulic pressure above 3000 psi inside the upper fixer.

Note2: The number of Hexagon Socket Bolts depends on actuator model AH35 (6)/ AH45 (8)/ AH65 (8)/ AH95 (12)/ AH110 (16).

AC Actuator Redress Kits

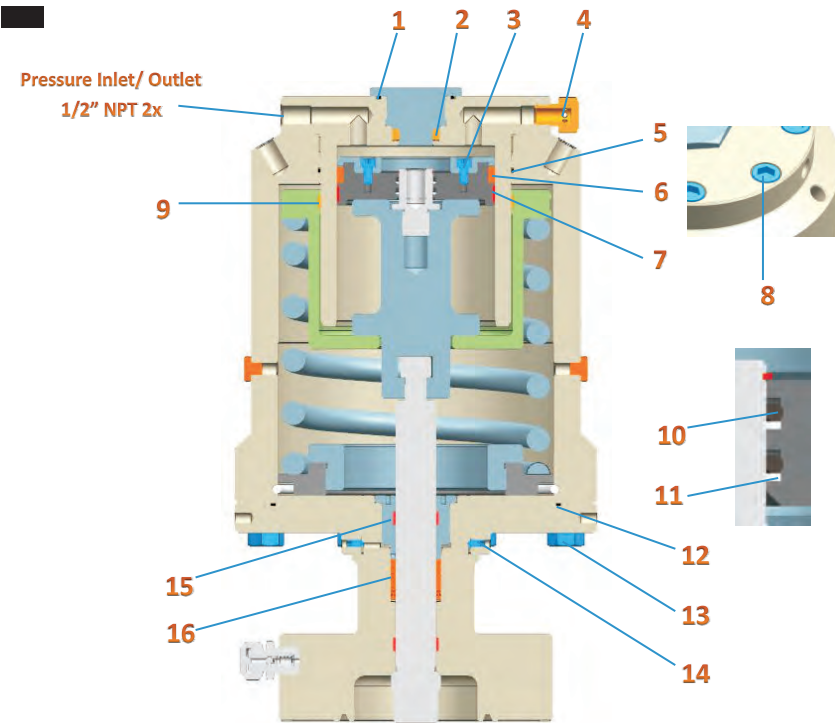

NOE stocks redress kits for all its actuator models. Kit contents are listed below for the three different redress kits available for the Model AC Actuator.

① Actuator Redress Kit Contents

#	Description	Qty
1	O-Ring(1)	1
2	Upper Shaft Seal	1
3	Hexagon Socket Bolt(1) (See Note1)	*
4	Rupture Disc Assembly (See Note2)	1
5	O-Ring(2)	1
6	Piston Seal	1
7	Wear Band(1)	1
8	Hexagon Socket Bolt(2) (See Note3)	*
9	Wear Band(2)	1
10	O-Ring(3)	2
11	Backup Ring	2
12	O-Ring(4)	1

② Actuator Attachment Kit Contents

#	Description	Qty
13	Bolt (See Note4)	*
14	Set Screw	2

③ Bonnet Redress Kit Contents

#	Description	Qty
15	Wear Band(3)	2
16	Packing Seal	1

Note1: The number of Hexagon Socket Bolts (1) depends on actuator model AC45 (8)/ AC58 (8)/ AC65 (8)/ AC95 (12)/ AC110 (16).

Note2: Rupture disc assembly is set at 3000 psi. Disc will rupture when hydraulic pressure above 3000 psi inside the upper fixer.

Note3: The number of Hexagon Socket Bolts (2) depends on actuator model AC45 (8)/ AC58 (8)/ AC65 (8)/ AC95 (12)/ AC110 (16).

Note4: The number of Bolts depends on actuator model AC45 (8)/ AC58 (8)/ AC65 (12)/ AC95 (16)/ AC110 (20).

DH Actuator Redress Kits

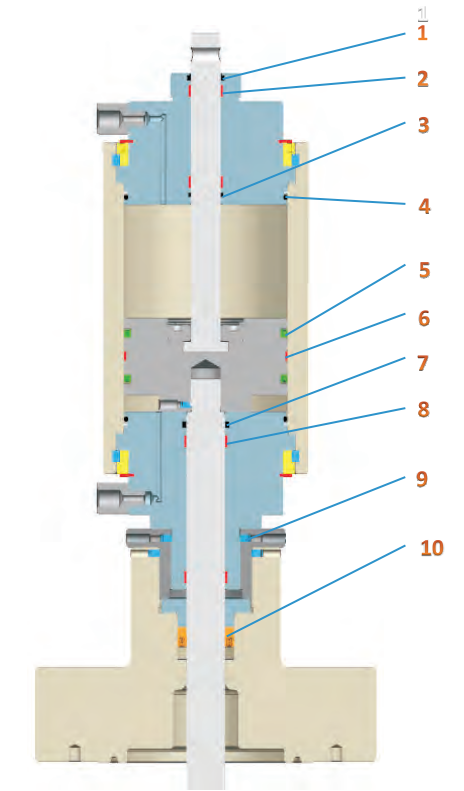

① Actuator Redress Kit Contents

#	Description	Qty
1	Rod Wiper	1
2	Wear Band(1)	2
3	Upper Shaft Seal	1
4	O-Ring/Backup Ring	2/2
5	Piston Seal	2
6	Wear Band(2)	1
7	Stem Seal	1
8	Wear Band(3)	2

② Actuator Attachment Kit Contents

#	Description	Qty
9	Set Screw	4

③ Bonnet Redress Kit Contents

#	Description	Qty
10	Stem Packing	1

NOE stocks redress kits for all its actuator models. Kit contents are listed below for the three different redress kits available for the Model DH Actuator.

Attachment: Tailrod Assembly Redress Kits

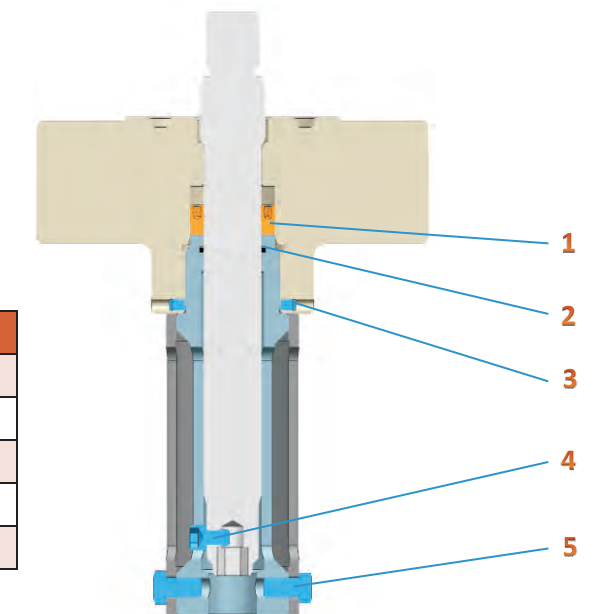

#	Description	Qty
1	Packing	1
2	O-Ring	1
3	Set Screw	2
4	Hexagon Socket Bolt	1
5	Bolt	2

GBM Gate Valve Redress Kits

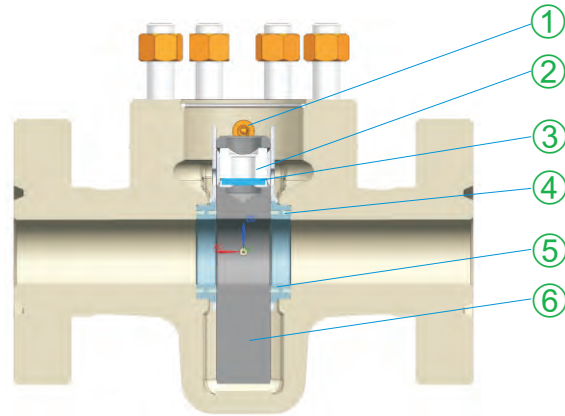

Valve Redress Kit Contents

#	Description	Qty
1	Bonnet Seal Ring	1
2	Gate Nut	1
3	Stem Pin	1
4	Seat Seal	4
5	Seat	2
6	Reverse/Direct Acting Slab Gate	1

NOE stocks redress kits for all of its product models. Kit contents are listed below for the Model GBM Gate Valve.

GBC Gate Valve Redress Kits

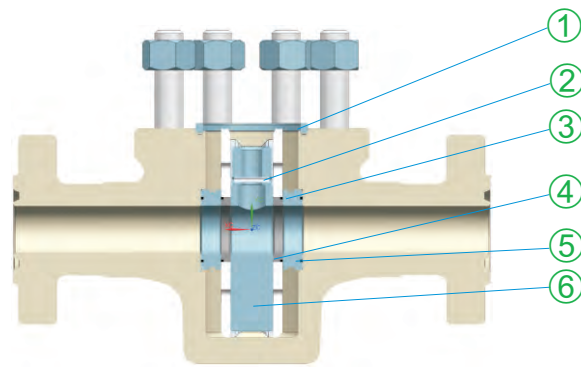

Valve Redress Kit Contents

#	Description	Qty
1	Bonnet Seal Ring	1
2	Stem Pin	1
3	Body Busing	2
4	Seat	2
5	Seat Seal	4
6	Reverse/Direct Acting Slab Gate	1

NOE stocks redress kits for all of its product models. Kit contents are listed below for the Model GBC Gate Valve.

GBS Gate Valve Redress Kits

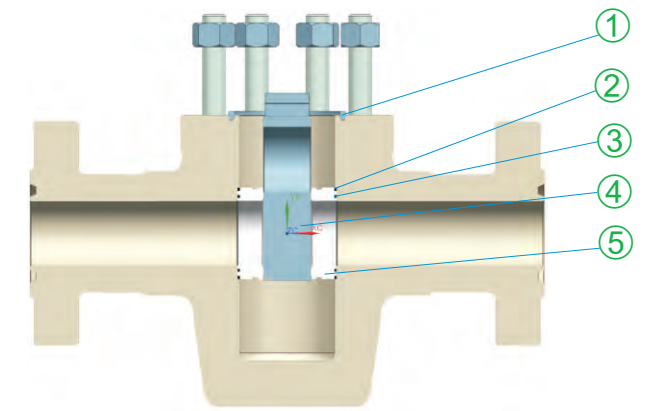

Valve Redress Kit Contents

#	Description	Qty
1	Bonnet Seal Ring	1
2	Seat Seal(1)	2
3	Seat Seal(2)	2
4	Reverse/Direct Acting Slab Gate	1
5	Seat	2

NOE stocks redress kits for all of its product models. Kit contents are listed below for the Model GBS Gate Valve.

GBW Gate Valve Redress Kits

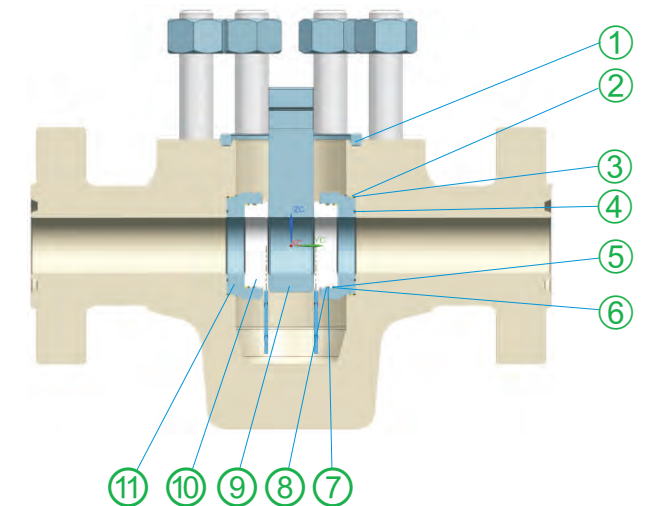

Valve Redress Kit Contents

#	Description	Qty
1	Bonnet Seal Ring	1
2	O-Ring Retainer(1)	1
3	O-Ring(1)	
4	O-Ring(2)	2
5	O-Ring(3)	2
6	O-Ring Retainer(2)	2
7	O-Ring(4)	2
8	O-Ring Retainer(3)	2
9	Reverse/Direct Acting Slab Gate	1
10	Seat	2
11	Body Busing	2

NOE stocks redress kits for all of its product models. Kit contents are listed below for the Model GBW Gate Valve.

Manual Override

The NOE manual override is designed to mechanically hold open a reverse acting gate valve when well servicing, logging, test or other intervention is required.

The override can be installed on any NOE spring return pneumatic and hydraulic actuators. The thrust bearing located at the end of the override stem reduces friction caused by high torque requirements and prevents damage to the actuator top shaft. A milled slot in the manual override housing allows the user to monitor the position of the override stem and determine the position of the gate valve.

All components of NOE manual overrides are stainless steel or coated carbon steel to ensure operability in severe operating conditions and are available for gate valves with bore size from 1-13/16" to 7-1/16".

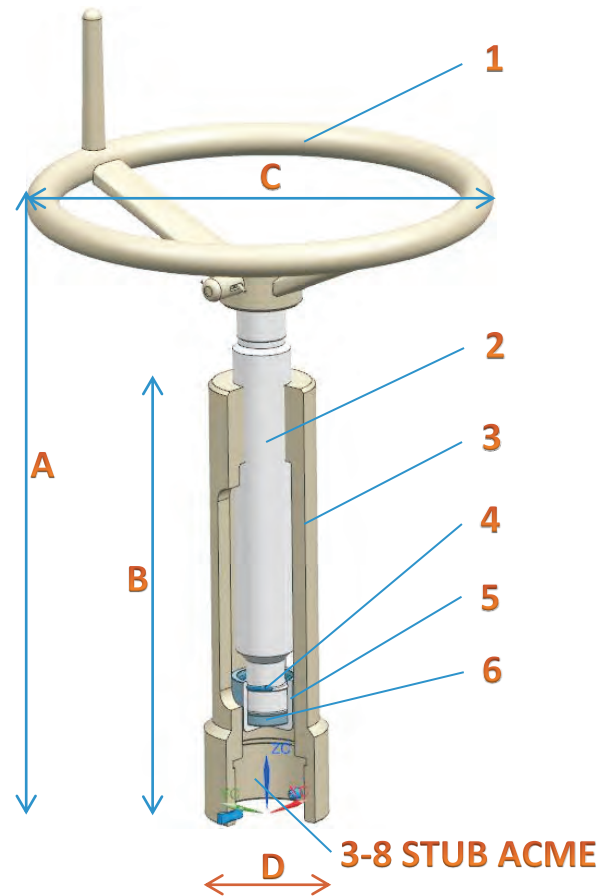

Parts List

#	Description	Qty
1	Hand Wheel Assembly	1
2	Stem	1
3	Housing	1
4	Retainer Ring	1
5	Retainer Housing	1
6	Thrust Bearing	2

Dimensions

A(in/mm)		B(in/mm)		C(in/mm)		D(in/mm)		Weight(lbs/kg)	
19.57	497	13.46	342	14.02	356	3.74	95	33	15
22.72	577	15	381	18.5	470	3.74	95	41	19

Lock Open Cap

The NOE manual lock open cap is designed to mechanically hold a reverse acting gate valve in the fully open position when 0 psi is present in the gate valve.

The NOE lock open cap can be installed on pneumatic and hydraulic actuators.

The lock open cap should only be used during storage and shipment. The purpose of the cap is to protect the upper shaft and to hold the valve in the open position. It should never be installed on a valve while service.

This device can be used on 1-13/16" to 7-1/16" gate valves with working pressures up to 10,000 psi.

The construction material is low carbon steel. The lock open cap has been coated to prevent corrosion during storage and shipment.

CAUTION:

Do not remove the lock open cap from an actuator without an application of min operating pressure. Failure to perform this sequential operation could result in injury to personnel.

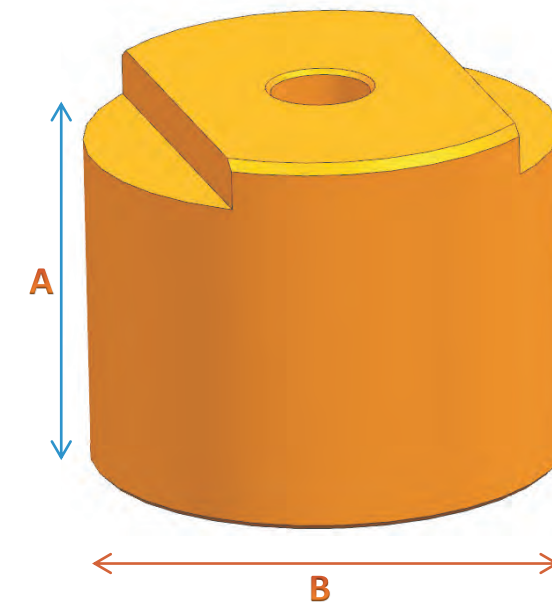

Thread	A(in/mm)		B(in/mm)		Weight(lbs/kg)	
3-8 STUB ACME	3	77	3.7	95	4	2